

SEWING FOCUS

TECHNICAL SEWING INFORMATION

SERVICEHOUSE



Quilting

Checklist for Quilting

Sewing Parameters: SCHMETZ Tip:

Needle size	NM	SIZE
	80 – 160	12 – 23
	Depending on the thickness of the material.	

Needle point In the industrial production of quilting, round points and ball points are used. The standard point style is the normal round point “R”, which produces a tidy seam appearance for all material thicknesses. Very thin, particular tightly woven or coated materials are also sewn with a “SPI” point, which enables exact piercing through the material layers. Depending on the material type ball points “SES” or “SUK” are also used.

Sewing thread Sewing threads in the form of continuous multi filament threads made of 100 % polyester or 100 % polyamide are used. Also core-spun threads are in use as hook/looper threads.

Machine For quilting yard ware multi-needle automated machinery is used. Complex decorative quilting is done by using 1-needle machines. In the production of mattresses and pads different multi-needle automated machinery is in use, which – depending on request – processes roll goods or partial cuts.

Other factors:

Thread tension The required thread tension depends on fabric, sewing thread and sewing machine. It should however be kept as low as possible in order to avoid seam puckering.

Stitch type Double lockstitch (stitch type 301), double chain stitch (stitch type 401) according to DIN 61400.

Stitch density Varies depending on quilting pattern and application area. The higher the stitch density the higher the connection between top cloth and fleece. Decorative quilting for garment and sports claim a stitch density of 4 – 5 stitches/cm, topstitching for pads and mattresses 3 – 4 stitches/cm. But: max. 6 – 7 stitches/cm.

Quick Reference for Typical Sewing Problems for Quilting

Symptoms	Effect	Cause
----------	--------	-------

Skip stitches/Thread breakage

No interlacing/interlooping of needle thread and bobbin/looper thread	Reduced seam strength	Incorrect thread tension
Needle thread breaks	Sub-standard, defective seam appearance	Incorrect needle system
Ravelling of the needle thread	Opening of the whole seam especially with double chain stitch	Needle incorrectly fitted
	Thread breakage after skip stitch	Hook or looper do not catch the thread loop formed by the needle thread
		Needle deflection due to extremely thick layers of material
		Mechanical damage to needle, throat plate, feed etc.

Fabric damage

Padding is protruding through stitch holes	Reduced tensile strength of the material	Needle size too big and/or wrong point style
Pulled out weft and warp threads	Sub-standard, defective seam appearance	Excessive sewing speed
Damage to the fabric	Reduced seam strength	Defective/worn out needles
Stitch holes visible, weft or warp threads destroyed		Unsuitable finish
		Damaged sewing accessories such as throat plate, feed etc.

Solution

NM SIZE



Point style



Thread



Machine

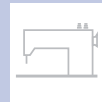

Adjust needle size to the material, amount of layers and thread size

Change needle regularly (after every shift or in shorter intervals depending on the stress)

Check needle eye and groove for damage, if in doubt: change needle

Check point for damage

Adjust sewing thread size to the needle size

Optimize thread tension

Optimize the hook/looper setting

Examine the thread guiding elements

Adjust the sewing accessories such as throat plate, feed etc. depending on material thickness and sewing thread/needle

Change worn out or defective sewing accessories regularly, such as thread guiding elements, hook/looper, throat plate etc.

Adjust needle size to the material and amount of layers

SPI
Acute round point

R
Normal round point

SES
Light ball point

CAUTION: After every change of shifts or in shorter intervals according to the needle stress we recommend to change the needle

Choose the right sewing thread size according to the needle size and the fabric

Adjust the sewing accessories such as throat plate, feed etc. depending on material thickness and sewing thread/needle

Check and adjust the material transport

Quick Reference for Typical Sewing Problems for Quilting

Symptoms	Effect	Cause
----------	--------	-------

Uneven seam appearance

Stitch sequence is irregular, resulting in a zig-zagging seam	<p>Pattern sequence not clean or warping, can lead to material not being usable anymore</p> <p>Reduced seam strength</p>	<p>Incorrect balance of thread tension</p> <p>Incorrect thread guidance</p> <p>Wrong point style</p> <p>Damaged thread guiding elements</p>
---	--	---

Needle breakage

	<p>Broken needle parts remain in fabric</p> <p>Material is damaged</p>	<p>Use of an undersized needle</p> <p>Needle deflection too heavy</p> <p>Needle size and material thickness are not adjusted to each other</p> <p>Damaged point, resulting in excessive penetration force</p>
--	--	---

Solution			
NM SIZE	Point style	Thread	Machine
			

Adjust needle size to the material and amount of layers		Optimize thread tension Check thread flow Choose the right sewing thread size according to the needle size and the fabric	Examine the thread guiding elements Check and adjust the material transport
---	--	---	--

Adjust needle size to the material and amount of layers CAUTION: It is advisable to change the needle after every shift or in shorter intervals depending on the stress			Check and adjust the material transport Adjust the sewing accessories such as throat plate, feed etc. depending on material thickness and sewing thread/needle CAUTION: After a needle breakage it is necessary to check the throat plate for damage
---	--	--	---

Selection of Point Style and Needle Size

Material	Number of layers	Needle size NM / SIZE	Point style
Tightly woven upper material (insulation wadding/ foam 30 – 100 g/m ²)	2 – 3	80 – 90 / 12 – 14	SPI acute round point R normal round point
Medium heavy upper material (insulation wadding/foam/ fleece up to 400 g/m ²)	2 – 3	100 – 120 / 16 – 19	R normal round point SES light ball point
Heavy upper material (insulation wadding/foam/ fleece up to 500 g/m ²)	2 – 3	130 – 160 / 21 – 23	R normal round point SUK medium ball point
Knit fabrics/warp fabrics	2 – 3	90 – 120 / 14 – 19	SES light ball point SUK medium ball point
Foils/laminates/ imitation leather (foam/insulation wadding/fleece)	2 – 3	90 – 130 / 14 – 21	R normal round point SPI acute round point
Glass fiber (foam/insulation wadding/fleece)	2 – 3	100 – 160 / 16 – 23	R normal round point

Contents

1. Technique of quilting
 - 1.1 Typical sewing problems
 - 1.2 Quality seams with the right sewing parameters
2. Selection of the right needle
 - 2.1 Needle size
 - 2.2 Point style
 - 2.3 Special needles for quilting
 - 2.4 Changing of the needle
3. Selection of sewing threads and stitch parameters
 - 3.1 Composition and size of the sewing thread
 - 3.2 Stitch type
 - 3.3 Stitch density
 - 3.4 Thread tension
4. Sewing machines for quilting
 - 4.1 Feed mechanism
 - 4.2 Throat plate/Throat plate aperture size
 - 4.3 Sewing speed
5. Our advice
6. SERVICEHOUSE –
An overview of our services

1. Technique of quilting

The technique of quilting has its origins in the 18th century. European immigrants took the method to America and within short time its popularity increased. Old fabric remnants were fitted together by hand and thus turned into new usable pieces of fabric. They were wadded and skillfully backstitched by hand to produce decorative blankets and wall hangings.

Apart from this craft work technique, which is still widespread today, machines were developed that enabled the joining of top cloth with insulation material industrially. Fabrics, knitwear, foils or laminates are used as upper material. The insulating materials consist of foam, polyester, cotton wool or wool felt. The end product's function determines the type of upper material as well as the filling material and the stitch type.

Today, quilted material can mostly be found in the areas of clothing, sports and interior, as well as in the production of mattresses, upholstered furniture and in coffin furnishings. Apart from their functional aspect, all quilted goods also fulfill an aesthetic aspect and put the greatest demands on machine, needle and thread.



1.1 Typical sewing problems

The area of application for quilted materials is always increasing. More and more, materials such as foils, laminates and glass fibers are used, which put entirely different demands on production than the classic fabrics and knitted fabrics. Since those materials are being processed on the same machine, not only machine setting, but also the right choice of needle and thread are of great importance.

Textiles in the high-quality area of interiors are subject to continuous fashion influences. Today high-tech automated quilting equipment allows the design of very complex patterns. This puts great demands on the interplay between needle, thread and sewing automat. Classic quilting machines work with up to 200 needles, arranged on a needle beam in two rows. The thread tension of each of the up to 200 threads is adjusted individually. It is difficult to achieve identical thread tension for all the threads, a precondition for avoiding the typical sewing problems.

Typical sewing problems are:

- Skip stitches/Thread breakage
- Fabric damage
- Uneven seam appearance
- Needle breakage

1.2 Quality seams with the right sewing parameters

Quality quilting seams should not only meet the demands of durability and tensile strength, they must also satisfy our aesthetic sense. All the sewing parameters which influence production have to be tuned in order to be compatible to each other: material, needle, thread and machine settings. If one parameter is changed the others must be checked and if necessary adapted. A regular control of all parameters is essential to ensure a successful and smooth production process.

Needle

2. Selection of the right needle

The key to a smooth seam and a perfect final product is first and foremost the selection of the right needle. Upper material and the type of filling material are the factors which determine the correct needle size and point style. Choosing the correct needle size and point style decreases skip stitches, thread breakage and material damage and therefore reduces shutdown time during the production process.

2.1 Needle size

Before deciding on a point style, needle size should be determined. It is important to bring this into line with the thread: the size of the eye of the needle and of sewing thread must be perfectly coordinated, since quilting machines and automats expose the thread to additional friction because sewing takes place not only in one direction. The choice of the needle size is also depending on the material to be sewn. While sewing quilting material it is always essential to look at the top cloth in combination with the filling material. The basic principle is: The finer the material, the finer the needle. However, if the padding material is very thick and not easily penetrable the size of the needle should be adjusted to the padding material.

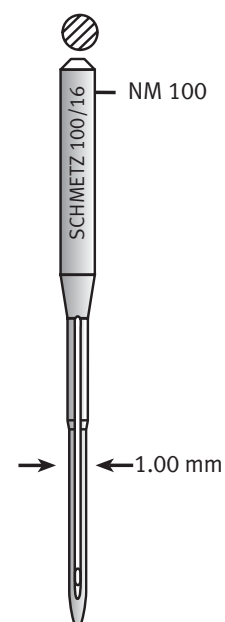

When sewing foils and coated material attention must be paid that the needle penetrates the material neatly and does not cause any additional damage. If the stitch hole is too big because a too large needle was used, the wadding may be able to pass through the stitch onto the material upper. This would definitely reduce the quality of the end product. If the fabric gets damaged even though the right needle size was selected, the point style of the needle will have to be checked. The wrong needle point can also cause fabric damage.

You can find an overview of recommended needle sizes in the table on page 6.

2.2 Point style

Apart from needle size, point style is also decisive for a smooth production process and an optimal final result.

In the production of quilting, round and ball points are used. In the case of round points, a distinction is made between the acute round point “SPI” and the normal round point “R”. The very slim “SPI” point is mostly used when there is a need for exact penetration of densely woven and thin materials.

In the case of combinations of fine, dense upper material and more rigid wadding material, the use of “R” points is recommended.



Seam appearance

The normal round point “R” with its conical shape counts as the standard point style and has many fields of application. This is the most frequently used needle point when quilting. Almost all fabric constructions and wadding materials can be pierced easily. Another field of application for the “R” point is the processing of foils, laminates and imitation leathers. In this case, there may be a combination of three different ma-

terials, if, in addition to upper material and wadding material, there is also a covering material for the bottom of the material. In such cases, the “R” point is considered the best compromise in order to fulfil all the demands of the different materials.

R normal round point



SPI acute round point



A further point style that is used for quilting is the ball point. Originally, ball points were only used in the production of knitted fabrics. However, experience shows that in the manufacture of certain kinds of fabric constructions the use of ball points does make sense. The hemispherical small ball point “SES” is used, which displaces the material/fabric threads during stitching. It is used when manufacturing fine knitted fabric or fabric constructions, where the “R” point causes material damage.

Needles with a medium ball point “SUK” are even more rounded than the light ball point “SES”.

The “SUK” point is used for coarser knitted fabrics and very tough and often twill woven fabrics. Due to its extremely rounded point, the “SUK” is able to displace even thicker fabric threads and thus avoids material damage.

SES light ball point



SUK medium ball point



2.3 Special needles for quilting

For many application in the area of quilting – especially the area of bedding and quilts – needles are used that are adjusted to these applications. As a rule, the eyes of “normal” needles increase in size with increasing needle size and are usually around 40 percent of the needle size NM. When quilting bedding and quilts, but for other applications as well, relatively thick needles of NM/Size 160/23 are used, with size of sewing thread usually being very low. Therefore, when using “normal” needles, there is a disparity between the size of the needle eye and size of thread.



Seam appearance

The thread is no longer being carried by the eye of the needle and the development of a clean and large thread loop for stitch building is obstructed. When the loop develops, i.e. when the needle moves upwards for the loop formation, the needle thread drops across the entire length of the eye to the bottom edge of the eye, before it can then be lifted and made into a loop.

Therefore, SCHMETZ produces needles with small eyes and an extra long point, specifically for applications such as bedding and quilts, which avoid the above mentioned problems and permit clean loop formation without skip stitches.

Needle with extra long point



Quilting machines with double lock stitch are also very common. They have a long shuttle instead of a rotary hook for building the stitch. These kinds of quilting machines require a special needle without scarf. SCHMETZ has the right kind of needle system as part of its range.

2.4 Changing of the needle

Minor damage to the needle point as well as needle tip wear and tear impair the quality of the end product. Depending on the number of material layers and type of padding material, the needle is exposed to different degrees of strains. Only a flawless point can ensure that the needle can penetrate the material layers without damaging them. Therefore, the needle should be changed often and at regular intervals.

SCHMETZ Tip:

Check the point of the needle regularly or change the needle at regular intervals.

Sewing thread

3. Selection of sewing threads and stitch parameters

In the production of quilted goods, aesthetic aspect always play a role. They are also characterized, however, by durability and sufficient elasticity. Quilted goods in the area of upholstered furniture and mattresses are subjected to a lot of strain during later use. The threads used should thus exhibit great abrasion resistance and tensile strength. For all uses of quilted goods, material as well as the quality of the sewing thread determine the quality of the end product to a high degree.

3.1 Composition and size of the sewing thread

For sewing quilted goods, mainly polyester or polyamide continuous multi filament threads are used. Rarely, core spun threads made of 100 % polyester or polyester threads with cotton are used. Polyester filaments are distinguished by a high degree of color fastness and light resistance. Quilting goods are therefore made for the area of clothing and sports wear as well as for interiors with polyester threads. In the area of mattresses and upholstered furniture, both types of polyester and polyamide filaments are used. If the quilted goods are cut after sewing, polyester filaments are favored. This is because the great elasticity of the polyamide thread causes the stitches at the cutting edges to loosen. Polyamide threads, however, are characterized by greater abrasion resistance and tensile strength. The advantages and disadvantages of the types of thread must be weighed up carefully.

Depending on sewing machine or sewing automat, polyester filament or core spun threads are used. Core spun threads are particularly suitable for types of overedge chain stitches for hemming cutting edges. Synthetic threads are not used only for the production of quilted goods for coffin fittings. The law prescribes threads that are bio-degradable. Instead, cotton and viscose threads are used.

3.2 Stitch type

In the production of quilted goods mainly two stitch types are used: the stitch type 301 (double lock stitch) and stitch type 401 (double chain stitch). For quilted goods in the field of garment, sports and interior the double lockstitch is exclusively used. The double chain stitch is used for connecting knitted fabrics and padding material as well as a variation in the field of upholstery and mattresses.

Stitch type 301 – double lockstitch

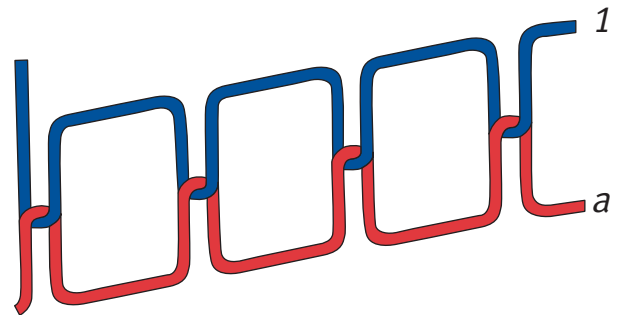

Stitch type 401 – double chain stitch (2-thread chain stitch)

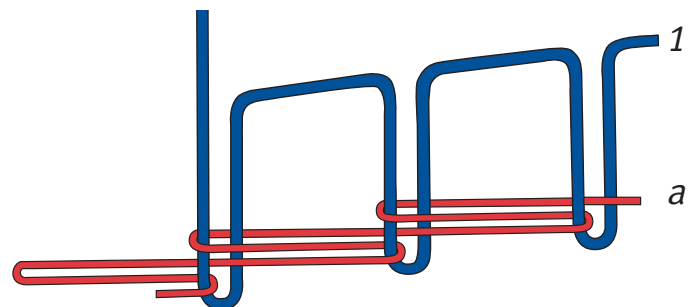

3.3 Stitch density

Stitch density depends on material composition, the quilting patterns and the desired strength of the seam. At the same time, thread size and the number of material layers are influencing the stitch density. The stitch density of decorative backstitches is between 3 and 5 stitches/cm. The quilting seam for upholstery and mattress panels should not exceed 3 stitches/cm.

3.4 Thread tension

In the production of quilted goods, a large number of materials are used in combination with many different padding materials. This requires individual setting of thread tension depending on fabric, sewing thread and machine. In general, thread tension should be as low as possible in order to achieve a smooth and pucker-free seam appearance. If thread tension is too high, this can cause problems when the quilted goods are being cut. The sewing thread strives for a tension-free state and loosens the stitches around the cutting edge.

Setting the correct thread tension is problematic when using quilting machines. Up to 200 individual thread tensions must be coordinated with each other. Uneven thread tension of the individual threads can cause the quilting patterns to move, or the sizes of the quilting patterns vary on one level. In general we recommend that thread tension should be checked with a special thread tension measuring device and adjust them individually for each kind of material.

Machine

4. Sewing machines for quilting

In the production of quilting machines 1-needle and multi-needle sewing automats are used. Distinctions are made between quilting automats and quilting machines. Automats are a type of apparatus where a sewing head moves through the fixed fabric. If the fabric moves through the apparatus, then it is called a quilting machine.

Multi-needle quilting machines process the running meter and mainly use the double lockstitch (stitch type 301). One must distinguish between two systems. There are, on the one hand, quilting automats where the pattern is determined across so-called pattern discs and who transfer their movement onto rollers. Those lead the material to the needles. The pattern is formed by the different movements of the rollers and the vertical movement of the needles. The pattern variation is limited because the rollers cannot move backwards in the case of quilting machines.

Additionally, there is the possibility of programming in the quilting pattern. The rollers' movements are controlled using a stepping motor. This allows the rollers to move backwards and make more complicated quilting patterns. The 1-needle

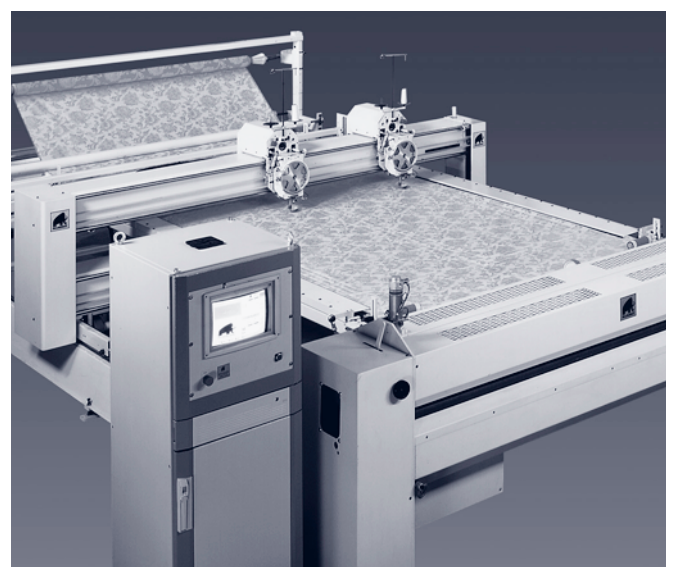

Pict. 1: 1-needle quilting automat/1-needle machine Mammut P2S/P1S

Source: Stutznäcker GmbH + Co. KG

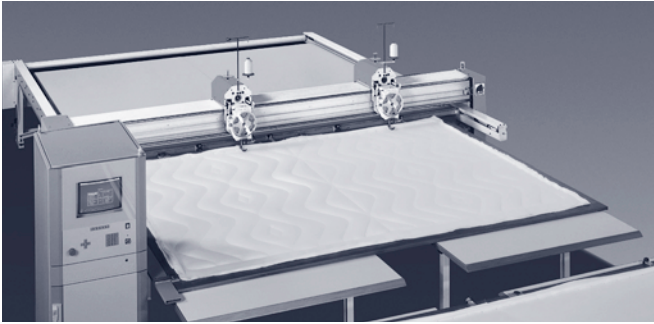

Pict. 2: 1-needle quilting automat/1-needle machine Mammut P2S/P1S

Source: Stutznäcker GmbH + Co. KG

quilting automat/1-needle machine uses a stentering frame (see pict. 1 + 2). The fabric is fixed into the stentering frame and a computer-controlled sewing head moves across the fabric. This method of quilting is somewhat wasteful and is only used for very expensive products.

Especially designed multi-needle sewing automats are used for sewing the running meter or partial cuts, especially in the production of mattresses and upholstery. Commonly used machines are mattress panel sewing apparatuses and border manufacturing systems. Mattress panel sewing apparatuses use the double lockstitch (stitch type 301) as well as the double chain stitch (stitch type 401). Border manufacturing systems automatically carry out the hemming on both cutting edges and also have an integrated double lock stitch facility for sewing on handles and other accessories.



Long-Arm Sewing Machine Quilting seams

(see pict. 3)

Multi-Needle Sewing Automat

(without illustration)

Quilting seams, for topstitching of large, very wide seams



Pict. 3: Long-arm sewing machine

Source: Stutznäcker GmbH + Co. KG

4.1 Feed mechanism

Quilting machines and automats do not use the feed as the classic feed mechanism. When quilting, material feed goes via rollers that lead the fabric through the machine. Attention must be paid that damages to the roller may cause material damage.

Multi-needle sewing automats use a roller feed as well as an additional needle feed, with needle and top feed as desired. Rollers often serve as top feed. Attention must be paid that the different feeding mechanisms must be well adjusted to one another in order to produce an optimal stitch appearance.

Quilting automats have a computer-controlled sewing head, which moves across the fixed fabric. Disruptions in data transmission in particular cause skip stitches and an uneven seam appearance.

4.2 Throat plate/Throat plate aperture size

Each specialist machine is fitted with a sewing set for each use and each sewing operations. Quilting machines and mattress panel sewing automats have a long throat plate with a pre-cut opening through which the needle can pass in order to form the loop. The so-called presser plate exerts pressure onto the material from above. This is the only way to form a stitch. Modern systems replace the presser plate with special presser feet, whose pressure is easily adjusted to the right material height.

Sewing automats and border manufacturing systems use sewing head apparatuses with an exchangeable throat plate. It is necessary to adjust the throat plate's opening to the thickness of the needle used, otherwise there is the danger that the material, especially the padding, gets caught up in the throat plate. This may lead to material damage and skip stitches. On the other hand, care must be taken that the needle and thread can pass the throat plate unimpeded.

4.3 Sewing speed

In the production of quilted goods, sewing speed is not very high. Depending on the pattern, quilting machines reach a sewing speed of 300 to 600 stitches/min. In the case of very simple patterns, quilting machines that use the double chain stitch reach a sewing speed of almost 1,000 stitches/min. The sewing speed of quilting automats also depends on the pattern and does not exceed 600 stitches/min.

5. Our advice

You can achieve damage-free quality seams if all the sewing parameters are precisely coordinated with one another.

Material, needle, thread and machine are the key variables. The **SCHMETZ SERVICEHOUSE** offers various service packages:

From recommending the ideal needle for your fabrics to sending out sample needles and providing assistance with special sewing requirements. In addition the **SCHMETZ SERVICEHOUSE** offers competent on-site advice on your production line and training courses for your employees.

**Challenge us –
let us show you our competence!**

Form to copy and fax: + 49 (0) 24 06 / 85-186

Do you have further questions about quilting?
Would you like support in solving your individual sewing problem?
Would you like recommendations on needle selection and sewability of your fabrics in advance of production?
Challenge the SERVICEHOUSE experts and take advantage of our offer.

We will be pleased to send you information on:

Our range of service:

Company name
Attention
Position
Address
Postcode/City
Country
Phone
Fax
E-Mail

CONSULTING

SAMPLE NEEDLES

Sample needles, tips and information

DOCUMENTED SEWING REPORTS

Sewing reports tailored to match your sewing goods as well as solutions for your complex sewing demands

EXPRESS CONSULTING

Express consulting by phone, fax or e-mail

INFORMATION

SEWING FOCUS

Sewing information for special industries and applications

PRODUCT FOCUS

Product information for special industries and applications

GUIDE TO SEWING TECHNIQUES

Manual for sewing industry

TRAINING/SYMPOSIUM

TRAINING-ON-SITE

Industry specific training including the latest information on needles, threads, machines and applications

SYMPOSIUM

Interdisciplinary knowledge sharing and exchange of expertise for skilled sewing industry staff