

SEWING FOCUS

TECHNICAL SEWING INFORMATION

SERVICEHOUSE



Protective Wear

Checklist for Sewing Protective Wear

Sewing Parameters: SCHMETZ Tip:

Needle size	NM 70 – 160	SIZE 10 – 23
--------------------	----------------	-----------------

Depending on the thickness of the material to be sewn, also available as SERV 7 version.

Needle point In protective wear manufacturing round points and ball points are mainly used. Cutting points should only be deployed for sewing leather (for example in the area of fire protection); as with all other materials there is the danger of damage.

Sewing thread	Fire and heat protection: Chemical and cold protection: Clean room:	Aramide sewing thread 100 % polyester and 100 % polyamide 100% polyester continuous multi filament yarn, special yarns, for example as antistatic finishing.
----------------------	---	---

Machine Industrial high-speed sewing machines with stitch type 301 (double lockstitch) and 401 (double chain stitch) are usually used. Also in use are overedge chain stitch and safety stitch machines, bar tack automatic machinery and other sewing automates (for example for sewing on bindings and pockets).

Other factors:

Thread tension The necessary thread tension depends on the sewing thread, the sewing machine and the number of layers to be sewn.

Stitch type Double lockstitch (stitch type 301) according to DIN 61400, double chain stitch (stitch type 401) according to DIN 61400, safety stitch and overedge chain stitch (various stitch types out of class 500) according to DIN 61400.

Stitch density The higher the stitch density, the better the seam strength. For the areas of fire and cold protection as well as protection against chemicals about 3 to 4 stitches/cm, for clean room clothing about 4 stitches/cm (always depending on the material and the layers to be sewn).

Quick Reference for Typical Sewing Problems in Protective Wear Manufacturing

Symptoms	Effect	Cause
----------	--------	-------

Skip stitches/ Thread breakage

No interlacing/interlooping of needle thread and bobbin/looper thread	Reduced seam strength, especially with double chain stitch	Incorrect thread tension
Needle thread breaks	Sub-standard, defective seam appearance	Incorrect needle system
	Opening of the whole seam especially with double chain stitch	Needle incorrectly fitted
	Thread breakage after skip stitch	Adhesion of melted residues, clogging of the needle eye and needle groove
	Jamming of the sewing thread due to stitch holes which are stuck together	Use of an oversized sewing thread in relation to the needle size
	Partly or whole melting through of the needle thread	Needle deflection due to extremely thick layers of material at cross seams
		Wrong sized aperture of throat plate, material is pulled into it or jammed and prevents the loop formation
		Overheating of sewing machine needle
	Mechanical damage to needle, throat plate, feed etc.	
	Incorrect thread guidance	

Needle breakage

	Broken needle parts remain in fabric	Needle deflection too heavy
	Material is damaged	Damaged point, resulting in excessive penetration force
		Needle size and material thickness are not adjusted to each other
		Wrong sized aperture of the throat plate
		Use of an undersized needle

Solution

NM SIZE



Point style



Thread



Machine



Use the SCHMETZ SERV 7 needle

Adjust needle size to the material and amount of layers

Change needle regularly (after every shift or after a shorter interval depending on the stress)

BLUKOLD needle with Teflon coating. This needle coating prevents or greatly reduces the adhesion of melted residues

CAUTION: Use of the BLUKOLD needle does not reduce the needle temperature which is caused by excessive sewing speed

Check needle eye and groove for damage, if in doubt: change needle

Check point for damage

Adjust sewing thread size to the needle size

Optimize thread tension

Optimize the hook/looper setting

Examine the thread guiding elements

Adjust the sewing accessories, such as throat plate, feed etc. depending on material thickness and sewing thread/needle

Reduce sewing speed

Change worn out or defective sewing accessories regularly, such as thread guiding elements, hook/looper, throat plate etc.

Use the SCHMETZ SERV 7 needle

Needle size as stated under 'Skip stitches/Thread breakage'

CAUTION: After every change of shifts or short intervals according to the needle stress we recommend to change the needle

Check and adjust the material transport

Adjust the sewing accessories, such as throat plate, feed etc. depending on material thickness and sewing thread/needle

CAUTION: After a needle breakage it is necessary to check the throat plate for damage

Quick Reference for Typical Sewing Problems in Protective Wear Manufacturing

Symptoms	Effect	Cause
----------	--------	-------

Feed puckering

Formation of undesirable waves along the seam	Shifting of material layers Reduced seam strength Uneven seam appearance	Incorrect adjustment of the sewing accessories, such as hook/looper, feed etc. Incorrect balance of thread tension Incorrect thread guidance Oversized needle and/or wrong point style Use of an oversized sewing thread and/or wrong sewing thread Presser-foot pressure too high
---	--	---

Material damage

Material damage	Reduced tensile strength of the material	Oversized needle and/or wrong point style
Pulled out weft and warp threads	Sub-standard, defective seam appearance	Excessive sewing speed
Stitch holes with melted residue of fabric threads	Reduced seam strength	Defective/worn out needles Wrong sized aperture of the throat plate
Stitch holes visible, weft or warp threads destroyed		Damaged sewing accessories, such as throat plate, feed etc.

Material shifting

Shifting of material layers	Fit is not precise Reduced seam strength	Very high and thick material layers Manufacturing of smooth materials Wrong adjustment of feed
-----------------------------	---	--

Solution			
NM SIZE	Point style	Thread	Machine
			

<p>Use of thinner needles</p> <p>Adjust needle size to the material and amount of layers</p>	<p>Check point for damage</p>	<p>Optimize thread tension</p> <p>Choose the right sewing thread size according to the needle size and the fabric</p>	<p>Use of special feeds (roller foot, teflon foot)</p> <p>Use of special sewing accessories</p> <p>Use of fine-toothed feed</p> <p>Correct thread guidance</p> <p>Adjust the sewing accessories, such as throat plate, feed etc. depending on material thickness and sewing thread/needle</p> <p>Adjust presser-foot pressure</p> <p>Examine the thread guiding elements</p>
--	-------------------------------	---	--

<p>Use the SCHMETZ SERV 7 needle</p> <p>Needle size as stated under 'Feed puckering'</p>	<p>R Normal round point</p> <p>SES Light ball point</p> <p>CAUTION: After every change of shifts or short intervals according to the needle stress we recommend to change the needle</p>	<p>Choose the right sewing thread size according to the needle size and the fabric</p>	<p>Adjust the sewing accessories, such as throat plate, feed etc. depending on material thickness and sewing thread/needle</p> <p>Check and adjust the material transport</p>
--	---	--	---

<p>Use the SCHMETZ SERV 7 needle</p> <p>Needle size as stated under 'Feed puckering'</p>	<p>Optimize thread tension</p>	<p>Adjust the sewing accessories, such as throat plate, feed etc. depending on material thickness and sewing thread/needle</p> <p>Reduce sewing speed</p>	
--	--------------------------------	---	--

Selection of Point Style and Needle Size

Material	Number of layers	Needle size NM / SIZE	Point style
Leather, leather lining	2	80 – 90 / 12 – 14	LR reverse twist point
	3 – 4	110 – 120 / 18 – 19	D triangular point (R normal round point)
Kevlar	2	90 / 14	R normal round point
	3 – 4	110 – 130 / 18 – 21	SUK medium ball point
	5 – 6	140 – 160 / 22 – 23	(SKF heavy ball point)
Cordura	2	90 / 14	R normal round point
	3 – 4	100 – 110 / 16 – 18	
	5 – 6	120 – 130 / 19 – 21	
Polyester and other synthetic materials	2	80 / 12	R normal round point
	3 – 4	90 – 100 / 14 – 16	
	5 – 6	110 – 130 / 19 – 21	
Tyvek	2	70 / 10	R normal round point
	3 – 4	80 – 90 / 12 – 14	(SES light ball point)
Film fabrics	2	80 – 90 / 12 – 14	R normal round point
PU coated fabric	2	80 / 12	R normal round point
	3 – 4	90 – 100 / 14 – 16	
False fur, fur	2	90 / 14	R normal round point
	3 – 4	110 – 120 / 18 – 19	(SES light ball point)
Wadding	2	90 – 100 / 14 – 16	R normal round point
Membrane foils	1 – 2	80 / 12	R normal round point
Cotton and synthetic materials	2	80 / 12	R normal round point
	3 – 4	90 – 100 / 14 – 16	
Heavy cotton	2	90 / 14	R normal round point
	3 – 4	10 – 120 / 18 – 19	
	5 – 6	130 – 140 / 21 – 22	

General recommendation: Use of the SERV 7 needle version with the appropriate point style



Contents

1. Manufacturing of protective wear
 - 1.1 Typical sewing problems
 - 1.2 Quality seams with the right sewing parameters
2. Selection of the right needle
 - 2.1 Needle size
 - 2.2 Point style
 - 2.3 SERV 7 needle construction
 - 2.4 Changing of the needle
3. Selection of sewing threads and stitch parameters
 - 3.1 Composition and size of the sewing thread
 - 3.2 Stitch type
 - 3.3 Stitch density
 - 3.4 Thread tension
4. Sewing machines for the manufacturing of protective wear
 - 4.1 Feed
 - 4.2 Throat plate/Throat plate aperture size
 - 4.3 Sewing speed
5. Our advice
6. SERVICEHOUSE –
An overview of our services

1. Manufacturing of protective wear

At the moment the market for protective wear is growing strongly with an optimistic prognosis for the future. Europe and especially Germany with a market share of 25 % are leaders in this field of application. The reason for Germany's leading position on one hand is derived from excellent technical know-how and on the other hand from constant research in the area of technical textiles.

There also is a growing demand for protective wear. The production and assembly of computers, for example in the chip production, the food industry as well as the medical development require clean room clothing which on one hand prevents the contact between human skin and the environment. On the other hand it has to allow comfortable work conditions. The protection against chemicals represents a different application area which is also in strong growth. Examples for the application of protective wear can be found in the chemical industry, hazardous waste disposal and agriculture.

You cannot do without protective wear in the area of heat and fire protection. Here the demands on the material and the manufacturing are very high and very different depending on the application. Fire brigades, refineries, glass and steel industry, off-shore and power stations – to name just a few – belong to this application area. Other areas of protection wear are bullet-proof vests, weather and cold protection, protection against the environment (for example dust, toxic gases), radiation protection, bacterial protection and protection against electrostatic charging.

During the production of protective wear safety and functional aspects are in the foreground. They have to be flame resistant, abrasion and wear resistant, chemical resistant and comfortable to wear. After the aspect of protection the comfort of the garment is the second most important criteria. Only clothes that are worn and do not limit a free movement are able to protect properly.

The consistent quality of the finished products is the decisive criterion in achieving optimum market positioning and enduring success. Quality assurance operated from the first phase of production is a tool for setting the required standard of final quality. For this reason it is important to make sure that the right needle size and point style are already

chosen during the preparation phase of work when dealing with complex technical textiles. Unfortunately the influence of the right needle on the final quality is often underestimated.

1.1 Typical sewing problems

The materials used in the area of protective wear are very different. Mostly technical textiles are used which were specially developed for a certain field of application. They have special properties which must not be impaired or destroyed during production. Here only one example is named:

Fire and heat resistant clothing consists of meta and para aramide fibres. Meta aramide offers a permanent flame protection and for this reason it is used for example for fire men protective clothing. Para aramids offer heat and cut protection. They have a very high temperature resistance and for this reason they are useful for protective wear in the area of blast furnaces. Preox fibres as well as glass fibre fabrics are also able to stand very high temperatures permanently. Additionally protective suits can be fitted with an antistatic finish which represents a further protective function.

Fabrics consisting of PVC fibres or polypropylene fibres with an extraordinary resistance against acids and bases are often used for chemical protection wear. Here special surface coatings and finishings offer further possibilities for a permanent protection.

Protective wear usually consists of different material layers. For this reason the manufacturing especially with many layers of technical textiles is not always unproblematic. Typical sewing problems in the sector of protective wear are:

- Skip stitches/Thread breakage
- Needle breakage
- Material displacement
- Material damage
- Feed puckering

1.2 Quality seams with the right sewing parameters

Due to the extensive variation of protective wear there are no particular sewing parameters for this area. A high amount of material layers and many different mostly synthetic materials result in different sewabilities. Additionally there are strict national and international regulations in the area of protective wear which have to be followed by the producers. The EN standard 340 is the basis for the general manufacturing of protective wear for the categories I, II or III.

Due to these demands and decisions the necessity arises to adjust all sewing parameters like sewing machine, sewing speed, sewing thread and needle individually according to the final product. The decisions and standards often determine the material and the sewing thread. As a result the needle often represents the only variable instrument.

Needle

2. Selection of the right needle

The determination of the right needle size and point style for the material to be sewn is among the most important decisions and responsibilities a quality assurance is faced with. The influence of the needle on the quality of the finished seam is often underestimated. It is possible to achieve big improvements in the production process and in the product quality by choosing the right needle size, needle type and point style.

Already during the preparation phase of work great consideration should be taken when choosing the needle in dependence to the material to be sewn, the number of layers, the sewing thread and the finishing of the fabric surface. If this process is neglected there can be no guarantee of a damage-free and high quality sewing.

In the area of protective wear you find many different materials with different properties and thickness. These circumstances require a large and very differing needle supply.

2.1 Needle size

The needle expands the fabric threads during penetration of the fabric. Choosing a too large needle diameter results in exceeding the physical tolerance limits in respect to the elongation of the fabric threads. This results in “bursting” i.e. damage of the fabric threads.

Especially in the area of cold protection and clean room clothing it is of great importance to choose the thinnest possible needle diameter. With cold protection wear it is important that the needle penetration holes are not too big otherwise the cold can penetrate from the outside to the inside. With clean room clothing it is also important to have the smallest possible needle penetration hole in order to guarantee the sealing of the seam.

Here the importance of a good preparation phase of work becomes visible again. This includes the determination of the right needle size in relation to the material. Depending on the thickness and finish of the material and given sufficient inherent elasticity in the fabric threads, no damage is to be expected if a suitable needle size is used.

An overview of the recommended needle sizes can be found in the table on page 6.

2.2 Point style

In the manufacturing of protective wear both SCHMETZ round points or ball points as well as cutting points are used.

The material combinations in the area of protective wear call for needles which can pass through the material layers easily with little exertion of force regardless of their thickness and compactness and without causing any fabric damage or needle deflection. This is the demand on the point style.

For most of the used fabrics for example heavy cotton, false fur, Kevlar, Cordura, polyester and other synthetic fabrics, wadding, membrane foils and PU coated fabrics it is advisable to employ a normal round point “R” or the light ball point “SES”. When sewing coarser fabrics the medium ball point “SUK” or the heavy ball point “SKF” should be used.

In comparison to the normal round point “R” the ball points have a small hemisphere at their tip and by this a piercing or damaging of the fabric threads is prevented. This guarantees a damage free displacement of the fabric fibres.

R normal round point



SES light ball point



SUK medium ball point



SKF heavy ball point



It should be taken care that the needles are chosen in a SERV 7 version when a high amount of layers is sewn. The SERV 7 needle reduces the needle deflection considerably and by this prevents skip stitches and needle breakages. Additionally it is often possible to choose one needle size smaller when using a SERV 7 version, for example NM 100 instead of NM 110. This is especially useful in the area of cold protection as well as clean room clothing as small needle penetration holes are desired here.

For the manufacturing of fabrics made out of rubber the acute round point “SPI” has proved itself. The needle size should not be chosen too small for these fabrics in order to prevent skip stitches.

SPI acute round point



You should always think carefully before using a cutting point. Cutting points cut the material when penetrating the fabric. In the area of protective wear they should only be used for leather in order to create no unwanted damage to

the material. Here a triangular point “D” or a reverse twist point “LR” can be used.

The reverse twist point “LR” is mainly used for the production of decorative seams. With the reverse twist point “LR” the incisions lie at an angle of 45° to the seam direction; this produces a decorative seam which is slightly turned to the left. When using any cutting point it is important to note that the stitch density is not too high. Otherwise the leather is perforated too much which will decrease the seam strength.

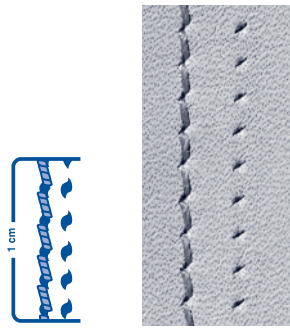
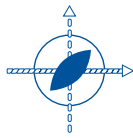

LR reverse twist point

In order to sew dry, hard leather types or coated fabrics well and economically needles with a “D” point (triangular point) are deployed. These needles have the best cutting effect of all cutting points. The symmetrical point shape ensures that the needle is almost never deflected, so that the seam is well centred, straight. The star shaped incision produced by the “D” point is never quite filled by the sewing thread, so that a very large stitch hole remains visible in the material.

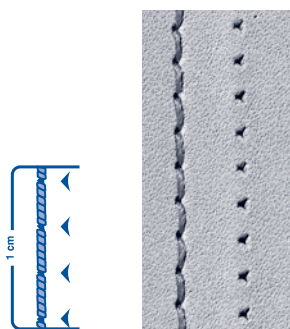
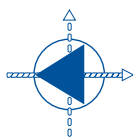

D triangular point

Caution: With increasing cutting effect bartacking at the beginning and at the end of the seam will cause damage to the sewing thread and to the fabric.

2.3 SERV 7 needle construction

The different sewing requirements and the high amount of material layers which are often sewn in the area of protective wear call for a needle which produces quality seams continuously without any interruptions. This is especially possible with a high performance needle like the SCHMETZ SERV 7 version.

Besides material displacement skip stitches are a frequent problem in the manufacturing of protective wear. Skip stitches occur during stitch formation when the thread loop is not caught by the hook or looper, interrupting the interlacing or interlooping of the upper and lower thread. Skip stitches impair the appearance and the strength of the seam (especially with double chain stitch) immensely. Skip stitches reduce the seam quality and turn a ready made protective suit into a reject.

SERV 7 is a special needle to prevent skip stitches and needle breakages. This needle type comes in various point styles—for the particular requirements of different materials. The distinctive features of SERV 7 needles are their specially shaped hump scarf and their extra blade reinforcement. The hump scarf extends the loop so that the hook or looper can catch it easily. This greatly reduces skip stitches.

The SERV 7 blade reinforcement makes the needle especially stable and far less likely to “bend” – a property which is of great importance especially for multi layer fabrics in the area of heat and cold protective wear. Needle breakages are thus minimized and the centric penetration produces a better seam appearance. The low deflection of the needle also prevents skip stitches.

SCHMETZ Tip:

Benefit 1: SERV 7 hump scarf produces optimum loop formation and prevents skip stitches.

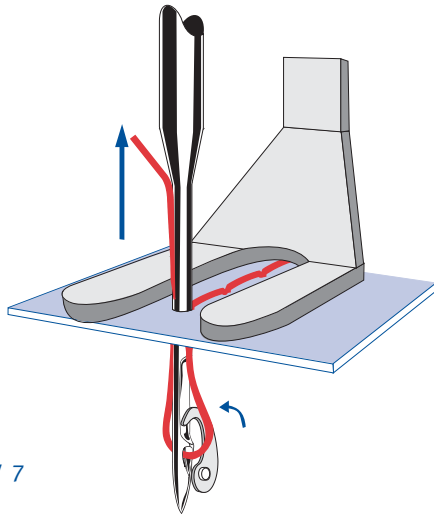

SCHMETZ SERV 7

SCHMETZ Tip:

Benefit 2: SERV 7 needle has higher stability increasing needle life.

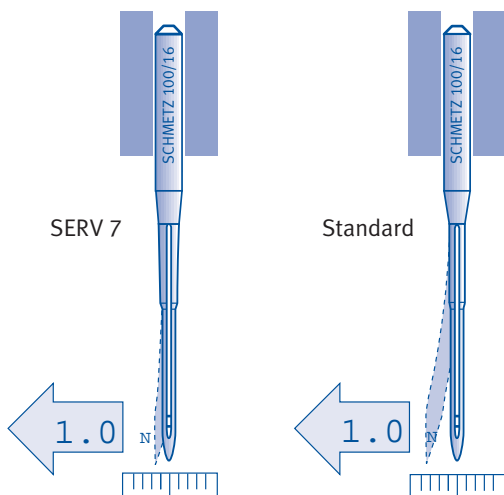

2.4 Changing of the needle

The regular changing of the needle should be a stated requirement in the performance specification of every quality control system. A continuous sewing process with highest quality demands is only possible if the needle is changed regularly. Worn out, smeared or bent needles

cause skip stitches, fabric damage and quality defects. In order to avoid this it is advisable to change the needle at the beginning of every shift. If the needle is strained heavily by high numbers of fabric layers or fast sewing speeds the needle should be changed more often. If in doubt about the time of use or the degree of wear it is advisable to change the needle at an early stage in order to avoid sewing problems.

Sewing thread

3. Selection of sewing threads and stitch parameters

The sewing threads used in the area of protective wear are often very specialized. Due to the high demands which they have to fulfill they are mostly technical sewing threads. The EN standard 340 is the basis for the general manufacturing of protective wear for the categories I, II or III. The material and the thread size are often already determined by the standards for the individual protective product.

3.1 Composition and size of the sewing thread

As a rule a meta aramide thread is dictated for fire and heat protective wear. Aramide threads are able to stand very high temperatures for a short period of time. They are heat resistant, non melting and self extinguishing. Aramide sewing threads start to disintegrate at a temperature of about 370° C. Additionally they have a good chemical resistance against mild acids and bases. The usual size used in manufacturing is NM 70/3, seldom NM 50/3.

For chemical protection core spun yarns made out of 100% polyester with the size No. 80 to No.100 are used. These sewing threads have a very good sewability. Seldom continuous sewing threads consisting of 100% polyamide with the size No. 80 are deployed as they have a very good resistance towards bases. But the problem with polyamide is the shrinkage of the thread.

When high chemical resistance is demanded continuous polyetheretherketon (PEEK) multi filament threads or sewing threads on the basis of PTFE (for example Teflon®) are

used. An alternative in production is the use of a conventional thread out of the area of core spun threads No. 80 to No. 100 and sealing the seam later by welding.

In the area of cold protection core spun yarns made out of 100 % polyester or 100 % polyamide with the strength No. 80 to No. 100 are often deployed.

The woven and knitted fabrics used in the area of clean room clothing are mostly made of continuous multi filaments, as these lose no fibres. Dust or loose fibres would cause a high reject rate in the application area of clean room clothing, for example in the chip production. For this reason threads mostly consist of continuous multi filament threads made of 100 % polyester. For closing seams sewn on overedge sewing machines textured sewing threads of the size No. 160 are deployed. Zippers and pockets are sewn on with a continuous polyester sewing thread with a strength of No. 120.

Looking at this rough summary it quickly becomes clear how specialized the yarn assortment is for each application. It is advisable to be informed by your thread producer.

3.2 Stitch type

The following stitch types are mainly used in the area of protective wear: the double lockstitch (stitch type 301), the double chain stitch (stitch type 401) and the overedge chain stitch (for example stitch type 502) often combined with the safety stitch seam.

The double lockstitch is often used for closing and attaching seams as it creates a very durable seam. Even if the thread breaks or a skip stitch occurs the seam does not open straight away.

Stitch type 301 – double lockstitch

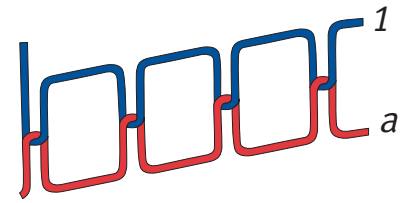

The double chain stitch offers a higher seam elasticity. For this reason it is especially useful for seams which have to take high elongation stresses.

Stitch type 401 – double chain stitch
(2-thread chain stitch)

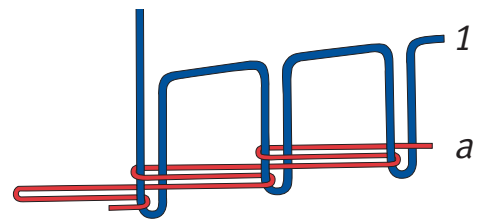

It is important that the seams of fire protection suits are not visible from the outside. For this reason the longitudinal seams on jackets and trousers are mostly sewn with a safety stitch. Clean room clothing is often throw away clothing which is only worn once. That is why a cost efficient production is in the foreground which is made possible through the high amount of stitches/minute with the safety stitch.

Stitch type 512 – 4-thread overedge stitch
(imitation safety stitch)

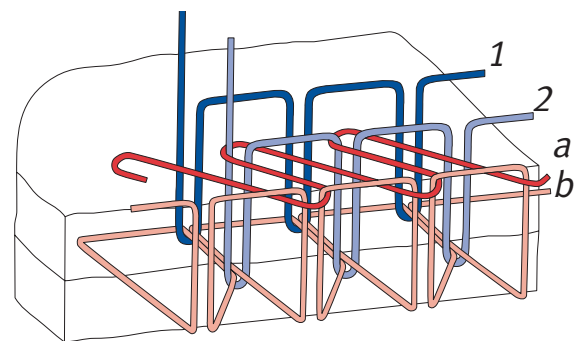

Welding as a substitute for a seam or the welding of a tape onto an existing seam is also an important production step in the area of chemical protection and clean room clothing. The use of an individual stitch type strongly depends on the demands on the seam and its position. In this area each producer develops his own system according to his quality and customer demands.

3.3 Stitch density

The stitch density should be adjusted according to the material, the number of layers, the deployed sewing thread and the desired seam strength as well as the seam elasticity.

There are many national and international regulations in the area of protective wear which relate to the properties of the garment. Indirectly the seam elasticity belongs to the properties which can among others be strongly influenced by the stitch density.

The named stitch densities can only be guide lines as they are chosen individually according to the demands and quality aspects of the consumer.

As a rule 3 to 4 stitches/cm are adjusted for closing and attaching seams on fire and cold protective clothing and for chemical protection.

A higher stitch density is chosen for clean room clothing to guarantee the strength and the tightness of the seam. Here the usual value for closing seams is 4 stitches/cm.

3.4 Thread tension

It is impossible to give a general statement on the thread tension in the field of protective wear. The spectrum reaches from values of 70 cN up to 190 cN. The perfect relation between sewing thread, needle, sewing machine and object to be sewn is always important for the thread tension. The amount of layers and the working method of the operator are also influencing factors. For these reasons the thread tension is always adjusted individually on each sewing machine by a technician.

It is important to note that rubber fabrics (for example in chemical protection) usually need a very high thread tension. With other fabrics one tends to set the thread tension low. The thread tension should be set in such a way that the stitch formation of the needle and bobbin thread can take place in an optimal way.

Machine

4. Sewing machines for the manufacturing of protective wear

A large variety of sewing machines – known to us from garment manufacturing – are in use in the manufacturing of protective wear. In the area of protection the selection of the sewing machine is strongly dependant on the end product: Fire and cold protective clothing requires machines for medium to heavy fabrics due to their higher amount of layers. Here 1-, 2- or 3-needle-machines with special feeds and additional accessories for the specific sewing operations are deployed. Clean room clothing requires machines for sewing of thin and sensitive fabrics. Chemical protection and clean room clothing is usually sewn on safety stitch machines and additionally welded in order to achieve a completely sealed seam. Bullet-proof vests are manufactured on medium weight 1-needle-sewing-machines.

Welding (for example hot air, high frequency) is an important production step in the area of protective wear. Many seams of thermoplastic materials are welded exclusively or additionally in order to guarantee a completely sealed seam.



Flatbed Sewing Machine Closing and attaching seams, flat seams, quilting



Long-Arm Sewing Machine Closing and attaching seams (for example for bulky fire protection wear)



Free-Arm Sewing Machine Closing and attaching seams

Feed-off-the-Arm Machine Flat seams

(without illustration)



Postbed Sewing Machine Securing of closing seams on small sections and curved patterns

Sewing Automates

(see pict. 1)

Sewing on pockets, sewing on buttons, button holes, bar tacking, sewing on bindings

Welding Machine

(see pict. 2)

Closing and attaching seams, sealing off of seams

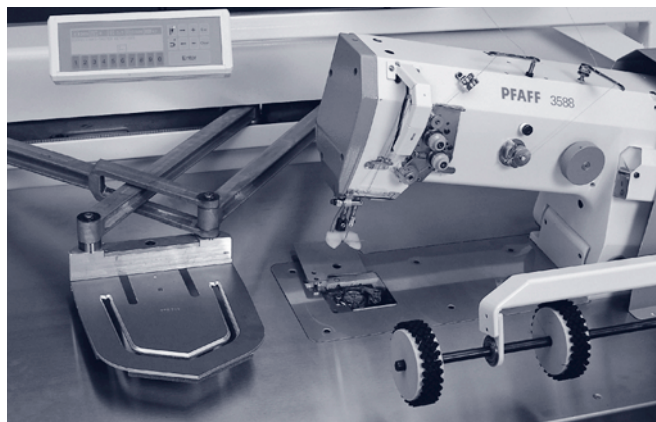

Pict. 1: Automatic Pocket Setter (3588)

Pict. 2: Ultrasonic Welding Machine (8310)

Source: Pfaff AG



4.1 Feed

Choosing the right feeding system is very important in order to guarantee an even material feed. Here the kind of material and the amount of layers which have to be transported have to be taken into consideration. When handling the thin, often rubber coated materials used in chemical protection the transport teeth are also of significance.



Compound feed with alternating presser foot top feed

Feed system which is used most often for medium to heavy materials (fire and cold protection) For smooth sewing of heavy and feed-critical materials with uniformly long stitches



Compound feed with alternating presser foot top feed with roller top feed

For smooth sewing of materials causing feed difficulties (for example rubber, coated fabrics)



Roller drop feed and/or roller top feed, needle feed

The roller feed makes smooth sewing of particular feed-critical materials with uniformly long stitches possible

4.2 Throat plate/Throat plate aperture size

Every sewing machine and every sewing automate is fitted with specific sewing accessories for the particular use or the sewing operation for which they are intended. These sewing accessories include the feed of the machine and the throat plate. The throat plate aperture size is adjusted in such a way that all needle sizes which can be fitted into the machine can pass easily. The throat plate can be changed according to demand.

It should be taken care that the size of the throat plate aperture is not too large for the chosen needle size. Otherwise there is a danger of the material being pulled into the aper-

ture of the throat plate. This causes fabric damage, skip stitches and thread breakages. Then a high quality seam and an unproblematic manufacturing process will no longer be possible.

If the aperture size of the throat plate is chosen too small in relation to the needle size or if the needle is deflected the needle cannot pass freely. This can also lead to fabric damage as well as needle breakages.

This emphasizes that choosing the right sewing accessories and changing them regularly is also an possibility to reduce sewing problems and should be a stated requirement in the performance specification of every quality control system.

4.3 Sewing speed

As a rule high sewing speeds are not usually reached in the area of manufacturing protective wear. But here the different sectors of protection have to be looked at individually. The often thick and heavy layers in the area of fire and cold protection can only be sewn well and undamaged at decreased sewing speeds. Here high sewing speeds only lead to a decrease of quality through thread breakages, skip stitches and needle breakages. Depending on the amount of layers and the position of the seam 1,000 to 2,800 stitches/min can be reached. The filmy layers of clean room clothing can be sewn on safety stitch sewing machines with a speed of up to 8,000 stitches/min. It is important to note that thermal damage in the form of needle smearing and material damage are the result of too high speeds when working with synthetic materials.

As a rule the sewing speed has to be adjusted to the material and the amount of layers to be sewn and the stitch type. As a principle: Optimal quality at high productivity.

5. Our advice

You can achieve damage-free quality seams if all the sewing parameters are precisely coordinated with one another.

Material, needle, thread and machine are the key variables. The **SCHMETZ SERVICEHOUSE** offers various service packages:

From recommending the ideal needle for your fabrics to sending out sample needles and providing assistance with special sewing requirements. In addition the **SCHMETZ SERVICEHOUSE** offers competent on-site advice on your production line and training courses for your employees.

**Challenge us –
let us show you our competence!**

Form to copy and fax: + 49 (0) 24 06 / 85-186

Do you have further questions about sewing protective wear?
Would you like support in solving your individual sewing problem?
Would you like recommendations on needle selection and sewability of your fabrics in advance of production?
Challenge the SERVICEHOUSE experts and take advantage of our offer.

We will be pleased to send you information on:

Our range of service:

CONSULTING

SAMPLE NEEDLES

Sample needles, tips and information

DOCUMENTED SEWING REPORTS

Sewing reports tailored to match your sewing goods as well as solutions for your complex sewing demands

EXPRESS CONSULTING

Express consulting by phone, fax or e-mail

INFORMATION

SEWING FOCUS

Sewing information for special industries and applications

PRODUCT FOCUS

Product information for special industries and applications

GUIDE TO SEWING TECHNIQUES

Manual for sewing industry

TRAINING/SYMPOSIUM

TRAINING-ON-SITE

Industry specific training including the latest information on needles, threads, machines and applications

SYMPOSIUM

Interdisciplinary knowledge sharing and exchange of expertise for skilled sewing industry staff



Company name
Attention
Position
Address
Postcode/City
Country
Phone
Fax
E-Mail